

W. C. COLEMAN.
LAMP.
APPLICATION FILED NOV. 17, 1909.

989,766.

Patented Apr. 18, 1911.

3 SHEETS-SHEET 1.

FIG. 1.

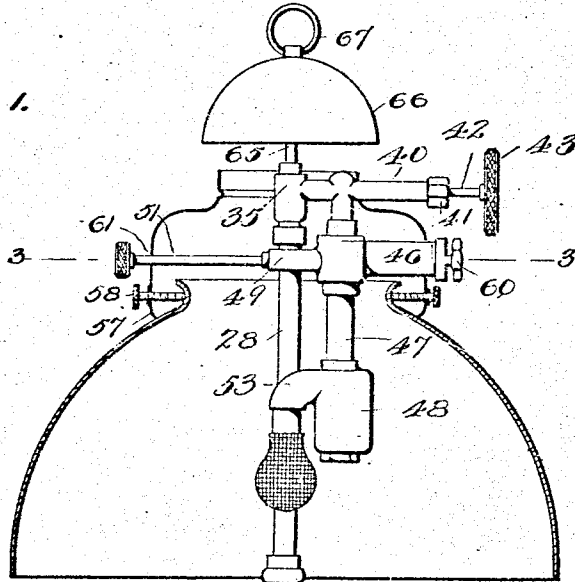

FIG. 4.

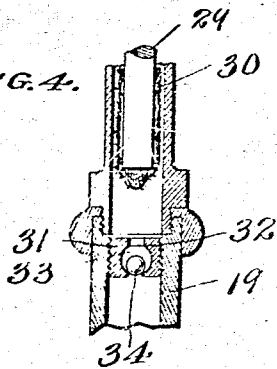
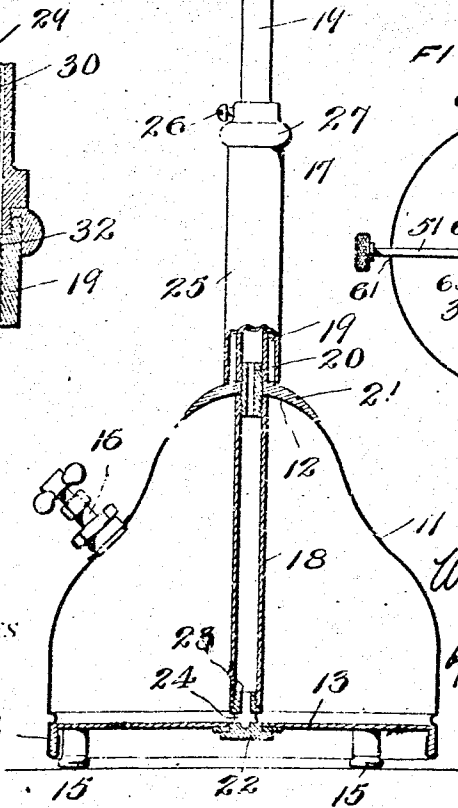
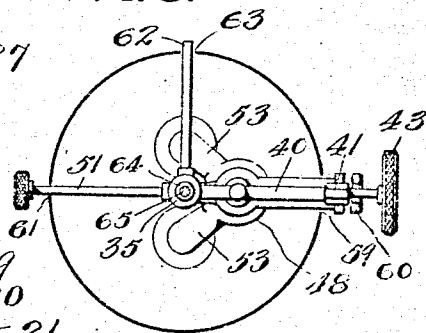

FIG. 3.



WITNESSES
C. K. Davis.
G. H. Ogilby.

William C. Coleman
INVENTOR
by McNeill and McNeill
Attorney &

W. C. COLEMAN.
LAMP.
APPLICATION FILED NOV. 17, 1909.

989,766.

Patented Apr. 18, 1911

3 SHEETS-SHEET 2.

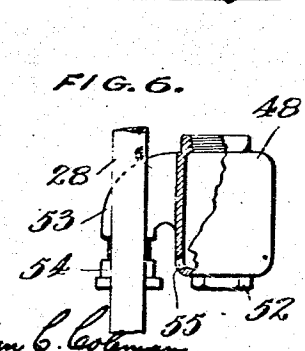
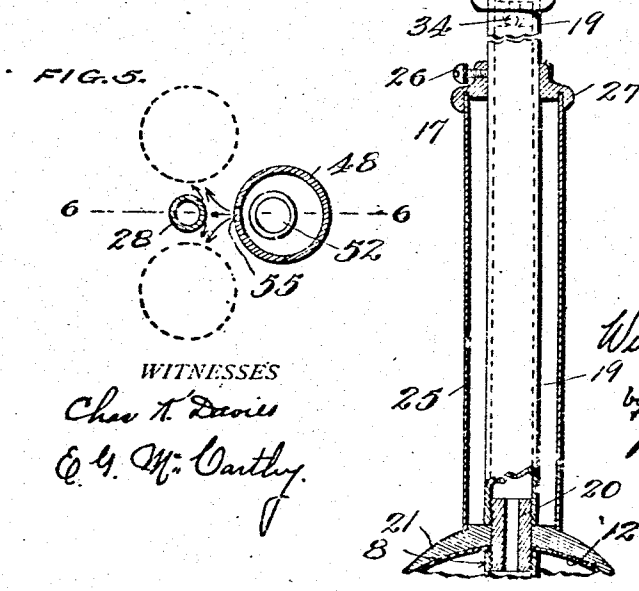
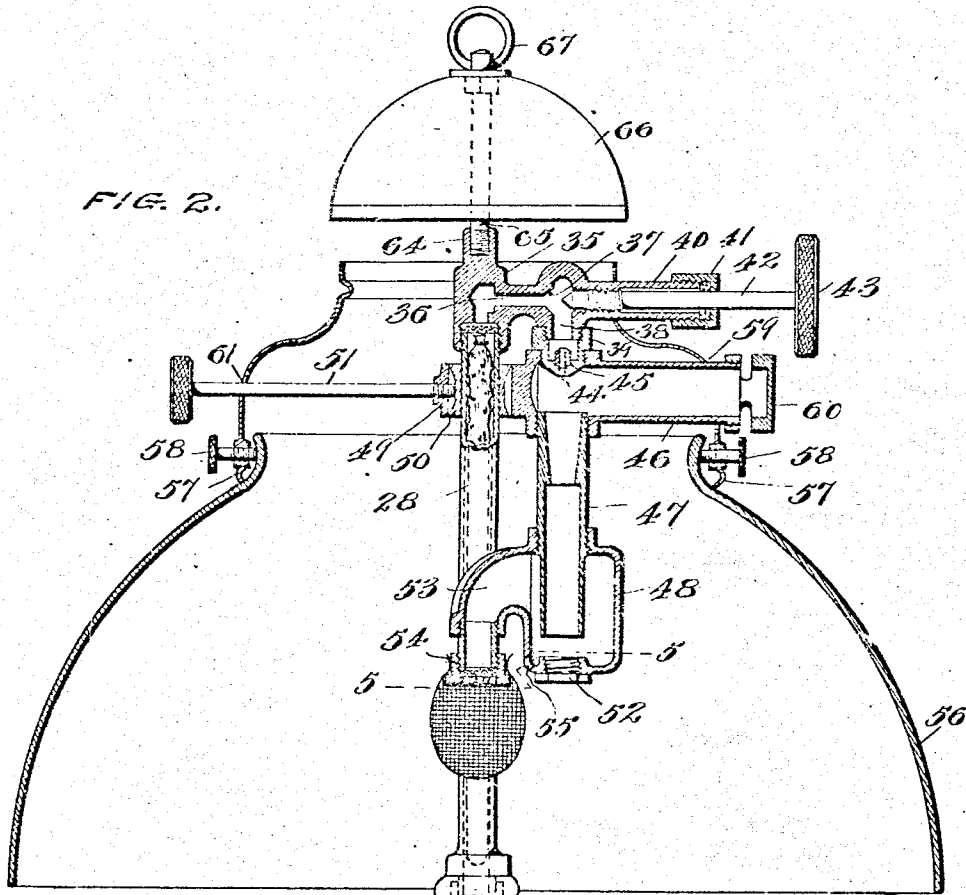

WITNESSES
Chas. H. Davis
C. G. W. Cantley

William C. Coleman
INVENTOR,
by McNeill & McNeill
Attorneys

W. C. COLEMAN.

LAMP.

APPLICATION FILED NOV. 17, 1909.

989,766.

Patented Apr. 18, 1911.

3 SHEETS—SHEET 3.

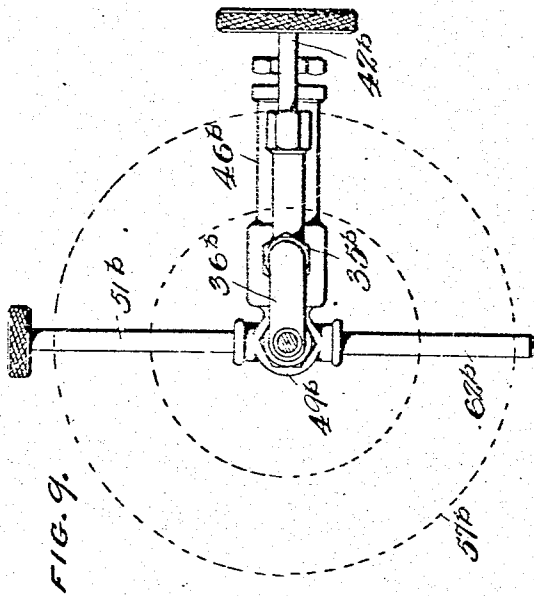

FIG. 9.

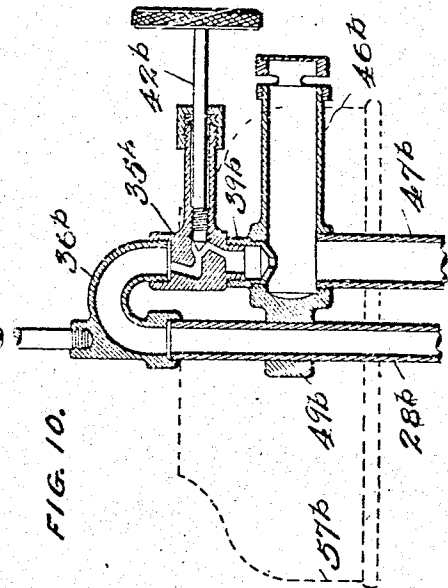

FIG. 10.

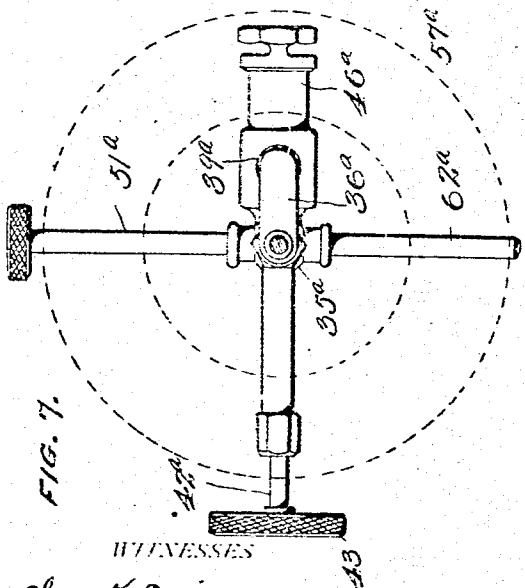

FIG. 7.

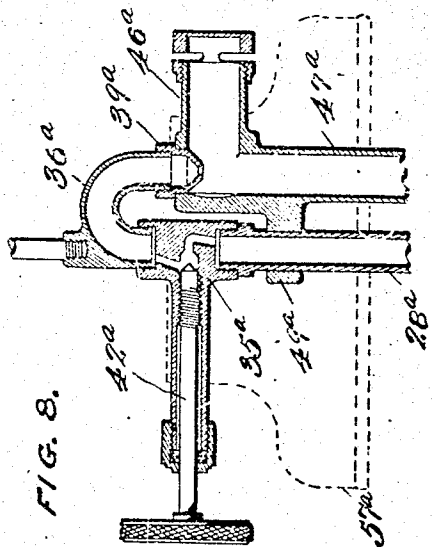

FIG. 8.

WITNESSES

Char. K. Davis
E. G. M. Canterbury.

INVENTOR,

William C. Coleman
by McNeill & McNeill
Attorneys.

UNITED STATES PATENT OFFICE.

WILLIAM C. COLEMAN, OF WICHITA, KANSAS.

LAMP.

989,766.

Specification of Letters Patent. Patented Apr. 18, 1911.

Application filed November 17, 1909. Serial No. 528,589.

To all whom it may concern:

Be it known that I, WILLIAM C. COLEMAN, a citizen of the United States, residing at Wichita, in the county of Sedgwick and State of Kansas, have invented certain new and useful Improvements in Lamps, of which the following is a specification.

The present invention relates to vapor lamps, and more particularly lamps of the type disclosed and claimed in my co-pending application, Serial No. 506,295, filed July 7, 1909. In one aspect, this invention involves certain improvements over the structure illustrated in said application.

One of the primary objects is to provide certain safety features, whereby danger of explosions is reduced to a minimum, in the first place, by producing an exceedingly strong font, in which the fuel conveying standard constitutes practically a tie bolt between the top and bottom walls of said font, secondly, by providing means which will effectively cut off the flow of fuel from the font, in case the upper portion of the lamp structure becomes broken off, and thirdly, by preventing accumulations of liquid fuel in the mixing chamber and producing a pilot light which will insure a maintenance of the flames at the burners.

Still another object is to provide novel, simple and effective means for supporting the shade by making certain elements of the lamp structure perform the functions of suspending devices.

An embodiment of the invention that is proving entirely satisfactory, is disclosed in the accompanying drawings, wherein:—

Figure 1 is a side elevation partially in section of the lamp. Fig. 2 is a sectional view through the same on an enlarged scale. Fig. 3 is a horizontal sectional view on the line 3—3 of Fig. 1. Fig. 4 is a detail sectional view through a portion of the standard, illustrating the safety valve. Fig. 5 is a sectional view substantially on the line 5—5 of Fig. 2, and indicating the operation of the pilot light. Fig. 6 is a detail vertical sectional view on the line 6—6 of Fig. 5. Fig. 7 is a plan view of a slightly modified form of construction. Fig. 8 is a vertical sectional view therethrough. Fig. 9 is a plan view of still a different embodiment of the cut-off and controlling valve structure. Fig. 10 is a vertical sectional view there-

Similar reference numerals designate cor-

responding parts in all the figures of the drawings.

In the embodiment disclosed, a base font 11 is employed, which is preferably of ornamental configuration, and has a top 12 and a bottom 13, the latter being comparatively heavy and flanged to the sides or body of the font, as shown at 14. Suitable supporting feet 15 of yielding material are secured to the flange. A combined filling nipple and air pump coupling 16 is mounted upon one side of the font, some distance below its upper end. A tubular standard, designated as a whole by the reference numeral 17, projects upward centrally from the font, and in the form illustrated, comprises sections 18 and 19, the section 18 being disposed within the font, the section 19 being arranged above the same, and said sections being connected by a tubular coupling 20 threaded into the adjacent ends of the sections. A cap 21 is located on the coupling between the sections, and bears upon the top 12 of the font. A nut has a head 22 bearing against the under side of the bottom and a neck 23 that extends through said bottom and is threaded into the lower end of the section 18. This neck is provided with inlet ports 24 that communicate with the interior of the font and with the interior of the standard section. It will thus be evident that the oil or liquid fuel under pressure within the font will be forced upwardly through the standard. A portion of the standard directly above the cap 21, is preferably surrounded by a handle sleeve 25 that bears upon the cap 21 and is held in place by a set screw 26 threaded through a collar 27, constituting an ornamental top to the said sleeve.

Connected to the upper end of the standard section 19 and constituting an extension thereof, is a vertical vaporizing tube 28, within which is placed a wick. This wick preferably comprises a metal core rod 29 surrounded by asbestos 30. The vaporizing tube, being straight, it will be evident that the wick may be inserted into and removed from the upper end of said tube. Located below the wick, and preferably at the juncture of the vaporizing tube with the section 19, is a valve seat plug 31 having an upper valve seat 32, and a lower chamber 33. Arranged in this chamber is a ball valve 34 that normally rests upon the bottom of the chamber, so as to permit the free upward

passage of the liquid fuel from the font into the vaporizing tube, as hereinafter explained.

Detachably threaded upon the upper end of the vaporizing tube, is a coupling head 35 having a horizontally disposed vapor passage 36 surrounded by a valve seat 37, said passage terminating in a downwardly extending outlet 38, to which is coupled a vapor delivery nozzle 39. The coupling has a horizontal extension 40 carrying a packing gland 41, and through this gland extends the stem 42 of a valve that is threaded into the extension and is movable into and out of coaction with the seat 37. A knurled head 43, secured to the outer end of the stem, constitutes means for actuating the valve. The nozzle 39 is threaded upon the coupling, and has a small discharge orifice 44 surrounded by an upstanding boss 45 fitted within said nozzle. The nozzle depends within the horizontal inlet stem 46 of a vertical Bunsen, or combined air and vapor conducting, pipe 47 that is disposed alongside the vaporizing tube 28. This pipe 47 is threaded through the top of a mixing chamber 48 that is thus supported by the pipe, the lower end of said pipe extending downwardly nearly to the bottom of the chamber. The tube 47 is supported by means of a collar 49 that surrounds the vaporizing tube 28, and is vertically slidable thereon, this collar also surrounding a fixed thimble 50 carried by the vaporizing tube 28 and having a peripheral groove therein. An outstanding set screw 51, having a comparatively long stem, is threaded through the collar and engages in the groove of the thimble, thus holding the parts in the position illustrated in Fig. 2.

The chamber 48 has a bottom opening normally closed by a plug 52, and is also provided with outstanding nipples 53 communicating with its upper portion and carrying depending burners 54 that also constitute mantle supports, said burners being disposed on opposite sides of the vaporizing tube 28. The chamber 48 furthermore has in its lower portion a vent opening 55 constituting a drain through which any liquid in the chamber can discharge. It will be observed by reference to Fig. 5, that this vent 55 is disposed directly opposite to the vaporizing tube 28. The reason for this arrangement will be explained in the description of the operation of the lamp.

The shade for the lamp is designated 56, and is carried as usual, by a suspending ring 57 having set screws 58 that engage the upper portion of the shade. This ring is provided with openings, one of which is designated 59, which opening receives the outer end of the air inlet stem 46, the air regulating device 60 being detachably threaded on said end. Another opposite opening

61 receives the outer portion of the set screw stem 51, and an outstanding pin 62, carried by the collar 41 and shown in Fig. 2, extends through another opening 63. It will thus be seen that the shade supporting ring 57 is suspended by the set screw, the stem 46 and the pin 62. The head 35 furthermore is provided with an upstanding projection 64, into which is threaded the stem 65 of a bell 66, this bell carrying a terminal ring 67, by means of which the lamp may be suspended if desired.

The operation of the structure is substantially as follows: Liquid fuel is placed in the font 11, and is placed under air pressure. As long as the valve 42 is closed, no fuel can pass through the lamp, but if said valve is opened, this fuel will pass upwardly through the standard into the vaporizer. The vaporizer, being initially heated by any suitable means, will change the liquid into vapor, which will pass through the passage 36, and discharge downwardly from the nozzle 39. The comparatively small orifice 44 will create a retarding pressure in the vaporizer, so that the upward flow of liquid fuel through the standard will be exceedingly slow, and consequently the valve 34, shown in Fig. 4, will maintain its inoperative position, permitting the passage of the fuel. The vapor passing downwardly through the pipe 47, will carry air with it into the mixing chamber 48, and the vaporized fuel will pass from said chamber through the nipples 53 to the burners, where it will be consumed, thus maintaining the usual mantles in incandescent condition.

It will be noted that a single controlling valve 42 is employed in the structure, which valve regulates the vapor, as well as controls the passage of fuel through the lamp. As a result, the light can be turned up or down, or immediately extinguished by means of said valve 42. The arrangement of the valve moreover places the packing and the handle outside the range of heat from the burner.

There are a number of important advantages for this structure, among which may be mentioned the following. The font is exceedingly strong to withstand any internal pressure that may be brought against it, the standard constituting a central tie bolt. The valve 34 also adds to the security of the device. As above explained, as long as there is a retarding pressure in the vaporizer, and the oil feeds slowly through the standard, this valve 34 will be in its open position, but if through any accident, the upper portion of the lamp structure should be broken off and the pressure thereby relieved above the valve, the increased force of the flow would cause the valve to seat and cut off such flow. The vent 55 is also an important feature, and performs two

functions. In the first place, it avoids any danger of the mixing chamber 48 becoming filled with liquid fuel, for such fuel will flow out of the vent, should it, from any cause, enter the mixing chamber. But a further, and perhaps more important function resides in the fact that it produces a pilot light. Of course when the lamp is in operation, a stream of vaporized fuel will flow from the vent, and the arrangement is such that the flame thus produced, will strike the vaporizing tube, be divided thereby and projected in opposite directions toward the burners, and into the range of the fuel flowing from said burners, as illustrated in Fig. 5. Now it is a well known fact that to secure complete combustion at the burner, the mixture of air and vapor is such that unless the flame is confined by the mantle, it is apt to "blow off," or in other words, become extinguished. It may sometimes happen that one or both mantles become accidentally broken when there is no one about to notice the same, and were it not for the pilot light, the lamp might become extinguished, as above explained. The vaporize as a consequence, would become cool, the liquid feed would flow upwardly there through discharge from the nozzle into the mixing chamber, and thus flow down upon the outside of the lamp. Should an accident of this kind occur with the present structure, the pilot light above described, would maintain the burners lighted at all times, and thus overcome the objection above described.

It will be noted that in this mechanism, the features of the lamp structure are employed as supporting means for the shade, thus reducing the number of elements and securing a symmetrical structure.

As an indication of how the mechanism may be modified, attention is invited to Figs. 7-10 inclusive. In Figs. 7 and 8, the vaporizing tube 28 has the controlling and cut-off valve casing 28^a secured to its upper end, the valve 42^a being horizontally disposed as before. The vapor conveying means 36^a terminates in a downwardly extending nozzle 39^a that is introduced into the upper end of the air and vapor-conducting pipe 47^a, which pipe has a horizontal inlet stem 46^a. In this form of structure, it will be observed that the valve is arranged between the vaporizing tube and nozzle, but over said tube. The pipe 47^a has a collar 49^a surrounding the tube and held in place by a set screw 51^a. The collar also carries an outstanding pin 62^a. The stem 46^a, set screw 51^a and pin 62^a constitute the support for the shade ring indicated in dotted lines, and designated 57^a. In Figs. 9 and 10, the arrangement more closely approximates that disclosed in Figs. 1-6 inclusive. The vaporizing tube is designated 28^b, and has

secured to its upper end a vapor conveying head 36^b in the form of an elbow that has secured to its free end the valve casing 35^b carrying a horizontal controlling and cut-off valve 42^b. Connected to the valve casing is the nozzle 39^b entering the horizontal inlet branch 46^b of a combined air and vapor conducting pipe 47^b. This pipe has a collar 49^b surrounding the vaporizing tube 38^b, and secured thereto by a set screw 51^b. A pin 62^b also carried by the collar, in connection with the set screw 51^b and inlet branch 46^b, constitutes means for supporting the shade holding ring 57^b.

From the foregoing it is thought that the construction, operation and many advantages of the herein described invention will be apparent to those skilled in the art, without further description, and it will be understood that various changes in the size, shape, proportion and minor details of construction may be resorted to without departing from the spirit or sacrificing any of the advantages of the invention.

Having thus fully described my invention, what I claim as new, and desire to secure by Letters Patent, is:—

1. In a lamp of the character set forth, the combination with a base font having a top and a bottom, of a tubular standard extending downwardly into the font and terminating short of the bottom thereof, a binding nut having a head bearing against the underside of the bottom and a neck passing through the bottom and threaded into the lower end of the standard, said neck having an inlet port within the font that communicates with the interior of the standard and opens through one side of the neck below said standard, and vaporizing, air mixing and burning means carried by and associated with the standard.

2. In a lamp of the character set forth, the combination with a base font having a top and a bottom, of a tubular standard comprising upper and lower sections located end to end, and a coupling having its upper end threaded into the upper section and its lower end threaded into the lower section, the lower section being located in the font, the upper extending above the same, a cap located on the coupling and clamped between the adjacent ends of the sections and bearing on top of the font, and vaporizing, air mixing and burning means carried by the standard.

3. In a lamp of the character set forth, the combination with a mixing chamber, of means for introducing air and vapor therinto, and an inverted burner connected to the upper portion of the mixing chamber and disposed alongside the same, said chamber having an opening in one wall that permits the escape of vapor to form a pilot light for the burner.

4. In a lamp of the character set forth, the combination with a mixing chamber, of means for introducing air and vapor thereinto, and a burner connected to the upper portion of the mixing chamber, said mixing chamber having a lower drain vent that also constitutes means for forming a pilot light that maintains a flame at the burner.

5. In a lamp of the character set forth, the combination with a mixing chamber, of means for introducing air and vapor thereinto, a burner connected to the upper portion of the mixing chamber, said mixing chamber having a lower drain vent that also constitutes means for forming a pilot light that maintains a flame at the burner, and means for deflecting said light into the range of vapor issuing from the burner.

6. In a lamp of the character set forth, the combination with a mixing chamber, of spaced burners connected and located adjacent thereto, said chamber having a vent forming a pilot light, and means for dividing the light and directing it toward the burners.

7. In a lamp of the character set forth, the combination with an upright vaporizing tube, of a mixing chamber located alongside the same and having burners disposed on opposite sides of said tube, and means for introducing vapor and air into the mixing

chamber, said chamber having a lower drain vent that forms a pilot light and directs the same against the vaporizing tube, said tube dividing the flame and directing it into the range of fuel issuing from the burners.

8. In a lamp of the character set forth, the combination with a standard, forming a vaporizer, of vapor and air mixing means movably mounted thereon and including an outstanding air inlet, an outstanding set screw for securing the mixing means against movement to the standard, and a shade holding device supported by the air inlet and set screw.

9. In a lamp of the character set forth, the combination with a standard forming a vaporizer, of vapor and air mixing means having a collar slidably mounted on the vaporizer, said means including an outstanding air inlet nipple, an outstanding set screw for securing the collar to the standard, an outstanding pin carried by the collar, and a shade suspending ring engaged with and supported by the outstanding inlet nipple, the set screw and the pin.

In testimony whereof, I affix my signature in presence of two witnesses.

WM. C. COLEMAN.

Witnesses:

D. S. COLEMAN,
GEO. D. SHIELDS.