

March 14, 1967

E. E. LITTLE ET AL

3,308,807

COLLAPSIBLE OVEN FOR CAMP STOVE

Filed Aug. 6, 1965

3 Sheets-Sheet 1

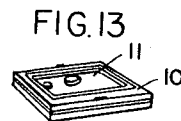
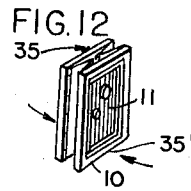
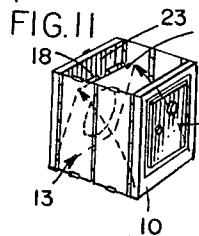
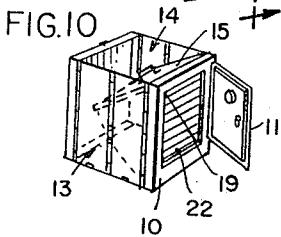
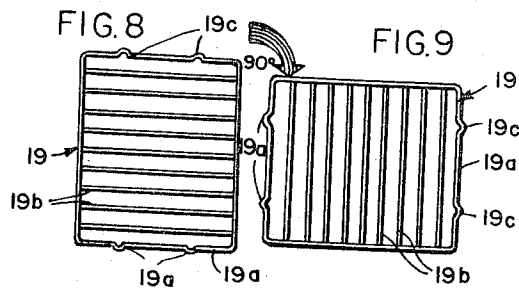
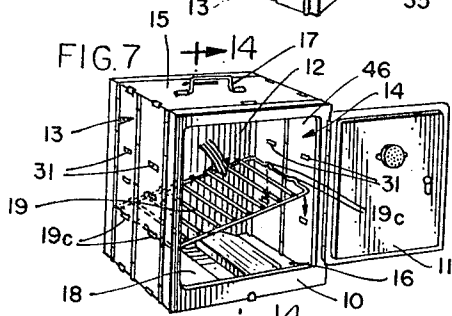
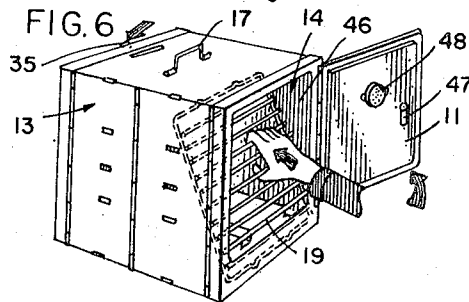
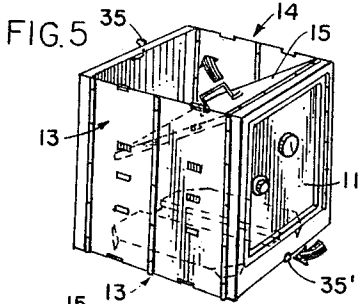
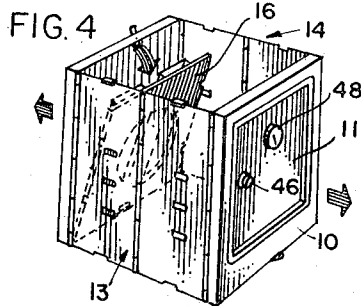
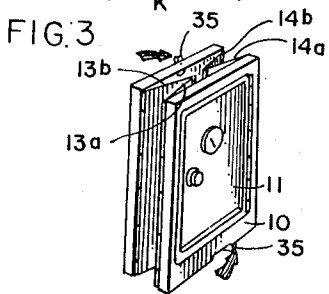
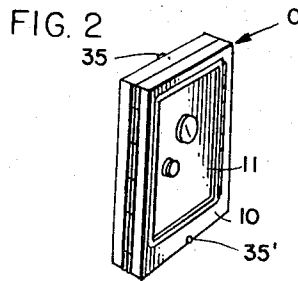
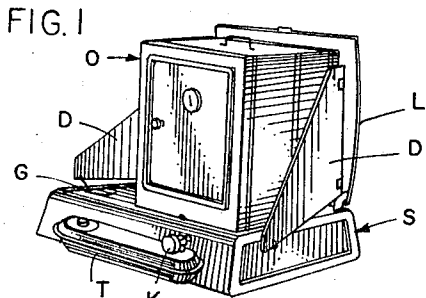

INVENTORS:  
ELLWOOD E. LITTLE  
WILBUR J. TOWNSEND

BY: *Dawson Pilton, Fallon, Livingston & Alexander*  
ATT'YS

March 14, 1967

E. E. LITTLE ET AL

3,308,807

COLLAPSIBLE OVEN FOR CAMP STOVE

Filed Aug. 6, 1965

3 Sheets-Sheet 2

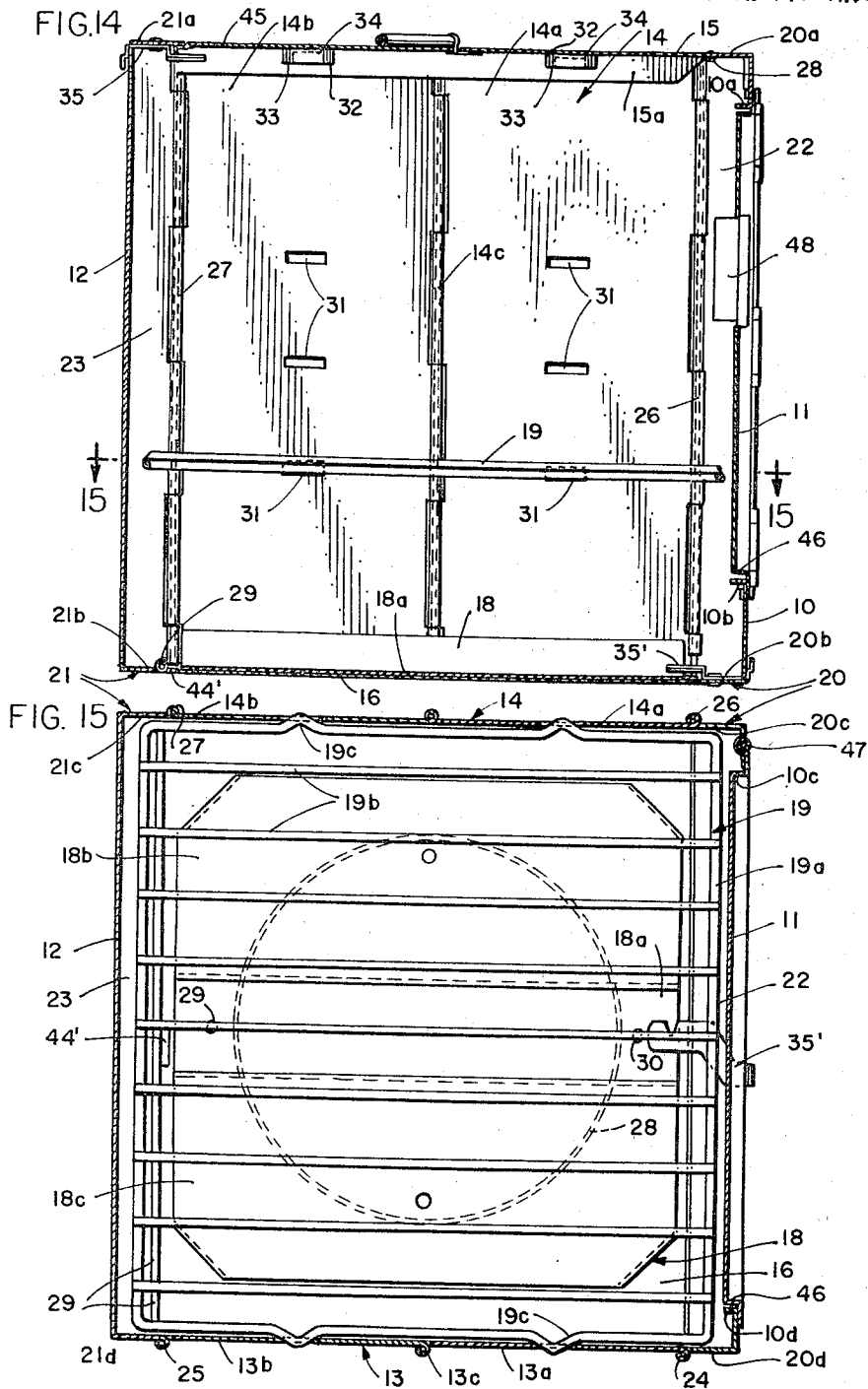

INVENTORS:  
ELLWOOD E. LITTLE  
WILBUR J. TOWNSEND

BY: *Dawson, Dilton, Fallon, Lungmug & Alexander*  
ATT'YS

March 14, 1967

E. E. LITTLE ET AL

3,308,807

COLLAPSIBLE OVEN FOR CAMP STOVE

Filed Aug. 6, 1965

3 Sheets-Sheet 3

FIG. 16

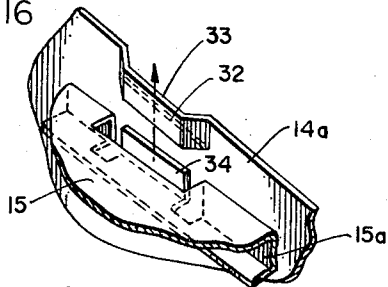

FIG. 17

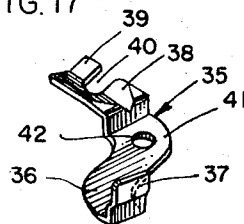

FIG. 18

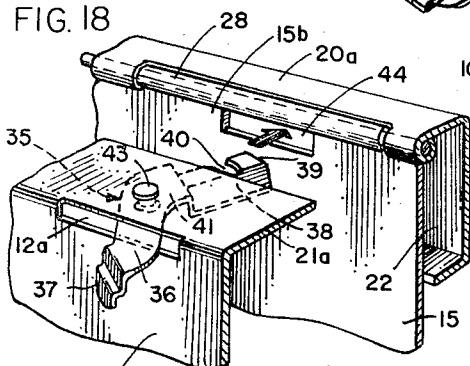

FIG. 20

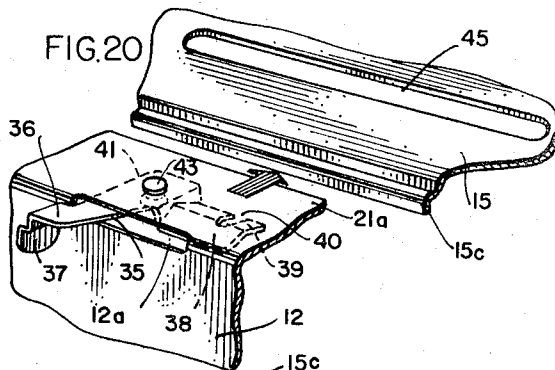

FIG. 19

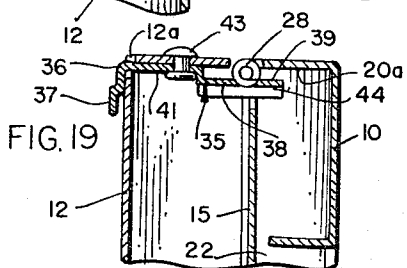

FIG. 21

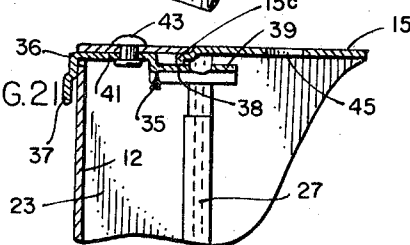
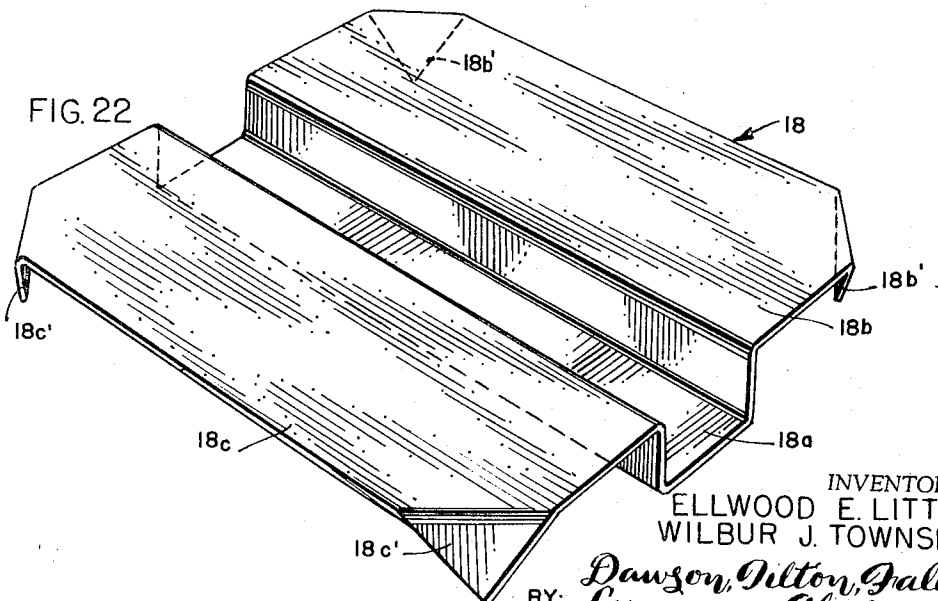

FIG. 22



INVENTORS:  
ELLWOOD E. LITTLE  
WILBUR J. TOWNSEND

BY: *Dawson, Dilton, Fallon,*  
*Lungmus & Alexander*  
ATT'YS

1

3,308,807

**COLLAPSIBLE OVEN FOR CAMP STOVE**

Ellwood E. Little and Wilbur J. Townsend, Wichita, Kans., assignors to The Coleman Company, Inc., Wichita, Kans., a corporation of Kansas  
 Filed Aug. 6, 1965, Ser. No. 477,697  
 8 Claims. (Cl. 126-275)

This invention relates to a collapsible oven for a camp stove, and more particularly to an improved construction of a camp stove oven, which facilitates the collapsing and storage of the oven and its associated components. The collapsible ovens constructed in accordance with the present invention have particular utility for use with the larger camp stoves, such as those having two or more burners. Although only one burner is operated to heat the oven, the larger top surface of camp stoves having two or more burners provides a better support for the oven. It will be understood, however, that the oven may be made in smaller sizes, and otherwise adapted for use on a single burner camp stove. The camp stoves may use any of the known liquid or gaseous fuels for such stoves, and will otherwise be operated in accordance with well known practices.

Collapsible ovens for camp stoves of various designs have been on the market in the United States for many years. While such ovens include folding panel members which permit the oven to be collapsed to a relatively compact condition for storage, the appearance of the ovens in collapsed condition has not been attractive, sharp edges and corners of the oven have been left exposed, and the oven in collapsed condition has not been as compact as would be desirable. In particular, no satisfactory means has been provided for storing certain components of the oven, such as the rack or grate, and the heat deflector or baffle. The racks, of which one or more may be provided, are supported within the oven to support cooking utensils during the operation of the oven, but must be removed from the oven to permit it to be collapsed. However, in connection with the storage and transportation of the oven in collapsed condition, it is undesirable to have the rack as a separate part. The heat baffle, which is normally mounted on top of the bottom panel of the oven, has prevented the bottom panel from being folded inside the oven in the collapsed condition, and when folded on the outside of the collapsed oven, it presents sharp edges and corners which are objectionable in appearance and interfere with the easy handling of the collapsed oven.

It is a general object of the present invention to provide a collapsible camp oven which substantially overcomes the problems and difficulties described above. More specifically, it is an object to provide a collapsible oven for a camp stove which provides a more attractive, convenient, and compact package in the collapsed condition of the oven. In this connection, it is an object to provide the oven with storage compartments for components such as the racks and heat baffles, the storage compartment being provided in the oven in its collapsed condition. Another object is to provide improved means for latching the oven panels in both erect and collapsed condition, and improved means for connecting the adjacent edges of the panels when the oven is in erect condition. Further objects and advantages will be indicated in the following detailed specification.

This invention is shown in an illustrative embodiment in the accompanying drawings, wherein:

FIGURE 1 is a perspective view of the oven seated on the top of a camp stove;

FIGS. 2-7 are perspective views illustrating successive stages in setting up the oven from its collapsed condition to its erect condition;

FIG. 8 is a front elevational view of a rack used with

2

the oven, the rack being shown in its storage orientation;

FIG. 9 is a further front elevational view of the rack of FIG. 8, the rack being shown in a different orientation for insertion into the erect oven;

FIGS. 10-13 are perspective views of the oven, illustrating successive stages in the collapsing of the oven;

FIG. 14 is a side sectional elevational view taken on lines 14-14 of FIG. 7;

FIG. 15 is a sectional plan view taken on line 15-15 of FIG. 14;

FIG. 16 is a fragmentary perspective view of the tab and socket means for connecting the edges of the panels;

FIG. 17 is a perspective view of the lever which is used in the latching means which are operative to latch the side and bottom panels in their erect condition, and the oven in its collapsed condition;

FIG. 18 is a fragmentary perspective view of the latch means as it operates to latch the oven in collapsed condition;

FIG. 19 is a fragmentary side sectional view showing the latch means of FIG. 18 in its secured position;

FIG. 20 is a perspective view of the same latch means as it operates to latch the top or bottom panels in erect condition;

FIG. 21 is a fragmentary side sectional view showing the latch means of FIG. 20 in its secured condition; and

FIG. 22 is a perspective view of the flame and heat baffle which is used with the stove and more particularly with the bottom panel thereof.

Looking first at FIGURE 1, there is shown a collapsible oven O which is mounted on the upper surface of a typical two-burner camp stove S. The stove is provided with a gasoline tank T, a burner control knob K, a grate G, a lid L, and wind deflectors D. The oven O has its bottom resting on the grate G, and is centered over one of the burners of the stove. To provide wind protection for the oven, the lid L may extend along the rear of the oven, while the wind deflectors D partially enclose the sides of the oven.

The oven is shown on the stove in its fully erect, operational condition. In FIG. 2, the same oven O is shown in its fully collapsed, storage condition. The oven of this invention is therefore characterized by having an erect position and a collapsed position, which are respectively illustrated by FIGS. 1 and 2.

FIGS. 2-7 illustrate different stages in setting up the oven from collapsed to erect condition. In FIGS. 10-13, different stages in the collapsing of the oven are illustrated. First, having particular reference to the oven in its erect condition, as shown, for example, in FIG. 7, it will be noted that the oven is of rectilinear configuration and has an interior cooking space enclosed by a front panel 10 which includes a door 11, a back panel 12, side panels designated generally by the numbers 13 and 14, a top panel 15, and a bottom panel 16. A handle 17 is attached to the top of top panel 15, and a flame and heat baffle or deflector 18 is mounted on the top of bottom panel 16. Within the oven, there is provided a removable and selectively positionable rack or grate 19.

As shown more clearly in FIGS. 14 and 15, the oven of the present invention includes a storage compartment providing flange means designated generally by the numbers 20 and 21, which respectively extend inwardly from the perimeters of front panel 10 and back panel 12. The flange means 20 includes a top section 20a, a bottom section 20b, and side sections 20c and 20d, while flange means 21 correspondingly includes a top section 21a, a bottom section 21b, and side sections 21c and 21d. These sections of the flange means 20 and 21 form extensions, respectively, of the top, bottom and side panels when the oven is in its erect condition. The flange means 20

provides a storage compartment 22, while the flange means 21 provides a storage compartment 23. Front panel 10, which includes door 11, forms a closure for the outside of compartment 22, while rear panel 12 forms a closure for the outside of compartment 23. The inner facing sides of the storage compartments 22 and 23 are open when the oven is erect.

Still having particular reference to FIGS. 14 and 15, it will be noted that the side panels 13, 14 respectively include vertical sections 13a, 13b, and 14a, 14b. These sections are hingedly connected at their adjacent inner edge portions as indicated at 13c and 14c. As indicated in FIG. 3, the sections 13a, 13b, and 14a, 14b, are hinged to fold inwardly so that the sections of each panel are superimposed when the oven is collapsed.

As shown more clearly in FIGS. 14 and 15, the outer vertical edge portions of the side panel sections 13a, 13b, and 14a, 14b, are hingedly connected to the respective inner edge portions of the flange means side sections. In the illustration given, panel section 13a is hingedly connected at 24 to flange section 20d, panel section 13b is hingedly connected at 25 to flange section 21d, panel section 14a is hingedly connected at 26 to flange section 20c, and panel section 14b is hingedly connected at 27 to flange section 21c. This hinging permits the side panel sections 13a, 13b, and 14a, 14b to fold inwardly as previously described, while remaining attached to the flange sections.

The adjacent one of the outer edge portions of top panel 15 is hingedly connected to the inner edge portion of the top section of one of said flange means. Also, one of the outer edge portions of the bottom panel 16 is hingedly connected to the inner edge portion of the bottom section of the other of said flange means. In the illustration given, top panel 15 is hingedly connected at 28 to top section 20a of flange means 20, while bottom panel 16 is hingedly connected at 29 to bottom section 21b of flange means 21. This arrangement permits the top and bottom panels to fold inwardly when said oven is collapsed to form closures for the facing sides of the storage compartments 22 and 23. In the illustration given, top panel 15 folds downwardly to provide a closure for the inner side of compartment 22, while bottom panel 16 folds upwardly to provide a closure for the inner side of compartment 23, as indicated, respectively, in FIGS. 10 and 11.

In accordance with the present invention, storage compartment 22 may be used for storing rack 19, while storage compartment 23 is employed for storing the baffle 18. In FIG. 10, the rack 19 is shown within the storage compartment 22, and in FIG. 11, the baffle 18 is shown as it is moved into the storage compartment 23 while remaining attached to the bottom panel 16.

As indicated in FIG. 15, bottom panel 16 includes a central opening 28, which may be centered over the top of the stove burner. The baffle 18 is mounted over the top of the opening, including a depressed central portion 18a and raised side portions 18b and 18c. The outer ends of central portion 18a may be connected to panel 16 by suitable rivets as indicated at 29 and 30 in FIG. 15. The configuration of baffle 18 is shown more clearly in FIG. 22. Support feet 18b' and 18c' may be provided respectively at the outer corners of baffle sections 18b and 18c.

Since the particular construction of baffle 18 is not of importance with respect to the present invention, it will not be further described herein. For the purpose of the present invention, the baffle 18 should be dimensioned for storage in one of the compartments such as the compartment 23. Preferably, baffle 18 projects upwardly from the top of bottom panel 16 by a distance no greater than the width of flange section 21 or the distance between rear panel 12 and hinge 29, thereby permitting baffle 18 to be fully received within compartment 23 when bottom 16 extends vertically.

The particular construction of rack 19 is also not of importance for the purpose of this invention. As shown in FIGS. 8, 9, and 15, the rack includes a perimetric frame 19a with spaced cross rods 19b. Opposite ends of the frame 19a are provided with insert extensions 19c, which cooperate with vertically-spaced slots in the side panels 13 and 14, such as the slots 31 as shown in FIG. 14. In the illustration given, rack 19 is rectangular, being longer in one dimension than the other, the insert extensions 19 being provided on the short sides. Correspondingly, front and rear panels 10 and 11 are somewhat wider than the side panels 13 and 14, while the front, rear and side panels have a height which is at least as great as the width of the front and rear panels 10, 12. Preferably, the front, rear and side panels have a somewhat greater height than the width of the front and rear panels, thereby permitting a snug fit for the rack 19 when extending in its long dimension between the sides 13 and 14, while the rack fits easily within the compartment 22 when its long dimension extends vertically therein. It will be understood that these dimensions can be varied considerably while still permitting rack 19 to be stored in the compartment 22. In general, means should be provided for detachably mounting the rack to extend horizontally across the interior space of the oven when the oven is erect, and said rack should be dimensioned for unmounted storage in the one of the storage compartments for which the top panel 15 provides a closure when the oven is collapsed.

To permit the oven to collapse to the most compact condition, it is desirable to have the top and bottom panels hingedly connected to their respective flange sections along lines which are offset outwardly with respect to the plane intersecting the hinge connections between the side panel sections and the side sections of the same flange means. For example, the hinge means 28 which connects top panel 15 with top flange section 20a is offset outwardly (toward front panel 10) from the plane formed by the hinge means 24 and 26, which respectively connect side panel 13 to side flange 20d, and side panel 14 to side flange 20c. Similarly, the hinge means 29 which connects the bottom panel 16 to bottom flange 21b is offset outwardly (toward rear panel 12) with respect to the plane of hinge means 25 and 27 which respectively connect side panel 13 to side flange 21d and side panel 14 to side flange 21c. The relationships of these various hinge means are shown more clearly in FIGS. 14 and 15. In this preferred construction, the sections 13a, 13b and 14a, 14b of the side panels may be folded inwardly in flat, superposed condition between the downwardly folded top panel 15 and the upwardly folded bottom panel 16.

A preferred means for releasably connecting the side edges of the top and bottom panels to the adjacent side edges, respectively, of the side panels is shown in FIG. 16. For example, the upper edge portion of side panel section 14a may be provided with an inwardly formed portion 32 which provides a socket or slot 33 for receiving a tab 34 which is formed in the downwardly-extending side flange 15a of top 15. Preferably, at least two of the cooperating tabs and sockets are provided at each of the adjacent edges of top panel 14, bottom panel 16, and side panels 13 and 14. With this construction, the tabs 34 and the sockets 32 may be formed integrally on either of the adjacent edge portions of the side and top panels or the side and bottom panels. As indicated in FIG. 16, the tabs 34 are insertable in the sockets 32 as the top and bottom panels are moved from their collapsed to their erect position.

In FIGS. 18-21, there is shown a preferred latching means, which functions as a dual purpose latch. As shown in FIGS. 20 and 21, the latching means is operative to latch the top and bottom panels in their erect positions, while as shown in FIGS. 18 and 19 the latching means is also operative for latching the oven in its collapsed position. More specifically, the latching means

5

should include at least two dual function latches, one of the latches being effective to latch the top panel in its erect position, the other of the latches being effective to latch the bottom panel in its erect position, and both latches being effective to latch the oven in its collapsed position.

In the illustration given, the latching means includes as its principal element a lever 11 designated generally by the number 35. As shown in FIG. 17, the lever 35 may comprise an angular or crank-shaped member having an outwardly-extending operating arm 36 terminating in a finger hold 37. Lever 35 also includes an inwardly-extending latching arm 38 which terminates in a laterally-extending attachment tab 39 adjacent a recess 40. The central portion 41 of the arm is provided with an opening 42 by means of which the arm may be pivotally attached to the underside of the flange section, as shown in FIGS. 18-21 with respect to flange section 21a. In the illustration given, a rivet 43 is employed for the pivotal attachment.

Referring now particularly to FIGS. 18 and 19, it will be seen that the top panel 15 is in its downwardly-extending, collapsed position where it closes the inner side of compartment 22. In alignment with the latch lever 35, and immediately below the hinge means 28, the upper portion of top panel 15 (as shown in FIG. 18) is provided with a slot 44 for receiving the outer end portion of the latching arm 38. The latch is secured when the recess 40 is extended around the portion 15b of the top panel which adjoins the left-hand side (as shown in FIG. 18) of recess 44. In this position, the attachment tab 39 will be within the compartment 22 behind the wall portion 15b, as shown more clearly in FIG. 19. In the illustration given, the upper portion of rear wall 12 in alignment with latching lever 35 is provided with a slot 12b through which extends the operating arm 36, the finger hold 37 being on the outside wall 12, as shown. This permits the lever 35 to be operated from the outside of the oven. In the unlatched position, the operating arm 36 will project outwardly beyond wall 12, while in the latched position, as shown in FIG. 19, the finger hold 37 will lie adjacent the wall 12.

In FIGS. 20 and 21, the lever latch 35 is illustrated performing its alternate function of holding the top panel 15 in its erect position. In FIG. 20, the lever 35 is shown in its unlatched position, with the operating arm 36 extending outwardly from the slot 12a. For the purpose of clarity, the top flange section 21a is shown in slightly separated relation from the top panel 15. However, it will be understood that the downwardly-turned edge 15c of the panel lies underneath the inner edge of the flange section 21a, as shown more clearly in FIG. 21. The latch 35 is then moved to closed position by means of finger hold 37, which causes the latching arm 38 to move beneath the edge 15c, thereby holding the top panel 15 in its erect, horizontal position, as shown more clearly in FIG. 21. The slots 45 in top panel 15 is a vent for the top of the oven. Another lever latch 35', identical in construction and operation to latch 35, is provided adjacent the bottom of front panel 10 for cooperating with a slot 44' in bottom panel 16.

In the illustration given, front panel 10, as shown more clearly in FIGS. 14 and 15, provides a central opening 46, which is defined by the integral, inwardly-turned flanges 10a, 10b, 10c, and 10d. One of the vertical sides of the door 11 is hingedly connected at 47 to the front panel 10 adjacent flange 10c. As shown, for example, in FIGS. 4 and 6, door 11 may be provided with a suitable latching means, including a knob 46 on the outside of the door for operating a latch 47 on the inside of the door, which engages the inside of flange 10d. Since the construction and operation of such latches are well known in the art, it is not believed it will be necessary to further describe them herein.

6

The oven may be provided with a suitable heat indicator. In the illustration given, a thermometer 48 is mounted in the upper portion of door 11, as indicated particularly in FIGS. 4, 6, and 14.

The oven as described herein may be manufactured by known procedures and techniques. Most of the components of the oven can be advantageously formed from sheet metal, such as low carbon steel. Steel wire may be used for forming the rack 19. Wherever possible, it is preferred to form the parts as integral members. For example, the flange sections 20a, 20b, 20c, and 20d, and 21a, 21b, 21c, and 21d can be respectively formed integrally with the panels 10 and 12, as shown more clearly in FIGS. 14 and 15.

#### OPERATION

The operation of the collapsible oven of this invention will be largely apparent from the foregoing description. However, it may be briefly summarized as follows, with particularly reference to FIGS. 2-13.

In FIG. 2, the oven is shown in its collapsed position, with the lever latches 35 closed. The latches are opened as indicated in FIG. 3, and the front and rear panels are pulled apart to expand the oven in the direction indicated by the arrows.

The bottom 16 is then swung downwardly into place, care being taken to insert the tabs in the corresponding sockets to connect the side edge portions of the bottom 16 with the adjacent edge portions of the sides 13 and 14. The bottom may then be latched in place by moving the lower lever arm to its closed or secured position, as indicated in FIG. 5.

The top 15 is then swung upwardly, as indicated by the arrow in FIG. 5, and latched in place by moving the upper lever 35 to its closed position, as indicated by the arrow in FIG. 6.

As the final step in the assembly, the door 11 is opened, as shown in FIG. 6, and the rack 19 is removed through the door opening 46. In the illustration given, the rack 19 has been stored with its long dimension extending upwardly, as shown more clearly in FIG. 8. The rack is then turned 90° to the position shown in FIG. 9. It is then reinserted through door opening 46 into the interior of the oven, and positioned in the selected slots at the desired elevation, as indicated in FIG. 7. The insert extensions 19c may first be extended through the slots in the side wall 13, as shown in FIG. 7, and then the other end of the rack moved downwardly, as indicated by the arrow, to insert the other extensions in the corresponding slots in the other side wall 14.

The oven may be collapsed by reversing the sequence just described. The required steps are illustrated in FIGS. 10-13. As shown in FIG. 10, the grate 19 is first removed, turned so that its long dimension extends upwardly, and reinserted for storage in the compartment 22. The top 15 is then released and swung downwardly to close the inside of the compartment 22.

The bottom panel 16 is then released and swung upwardly, as shown in FIG. 11, the baffle 18 being swung into the compartment 23 for storage therein.

The sides 13 and 14 are then folded inwardly, and the oven collapsed, as shown in FIG. 12. The latches 35 are then moved to their secured position to lock the oven in its collapsed condition, which is shown in FIG. 13.

While, in the foregoing specification, this invention has been described in relation to a preferred embodiment thereof, and many details have been set forth for purpose of illustration, it will be apparent to those skilled in the art that the invention is susceptible to additional embodiments and that certain of the details described herein can be varied considerably without departing from the principles and scope of the invention.

We claim:

1. In a collapsible oven for a camp stove having stable erect and collapsed positions,

said oven being of rectilinear configuration and having an interior space enclosed by front, back, side, top and bottom panels,  
 the construction comprising:  
 storage compartment-providing flange means extending inwardly from the perimeters of said front and back panels,  
 said flange means including top, bottom, and side sections forming extensions, respectively, of said top, bottom, and side panels when said oven is in its erect position,  
 the inner facing sides of the storage compartments provided by said flange means being open when said oven is erect,  
 said side panels including vertical sections hingedly connected at their adjacent inner edge portions to fold inwardly so that the sections of each side panel are superposed when said oven is collapsed,  
 the outer vertical edge portions of said side panel sections being hingedly connected to the respective inner edge portions of said flange means side sections, one of the outer edge portions of said top panel being hingedly connected to the inner edge portion of the top section of one of said flange means,  
 one of the outer edge portions of said bottom panel being hingedly connected to the inner edge portion of the bottom section of the other of said flange means,  
 each of said top and bottom panels being foldable inwardly when said oven is collapsed to form a closure respectively for one of the said facing sides of said storage compartments, and  
 a flame and heat baffle mounted on the top of said bottom panel and projecting upwardly therefrom,  
 said baffle being dimensioned for storage in the one of said storage compartments to which said bottom panel provides said closure,  
 said baffle being movable into a storage compartment when said oven is collapsed while remaining attached to said bottom panel.

2. The collapsible oven construction of claim 1 wherein said oven also includes a support rack, and means for detachably mounting said rack to extend horizontally across said interior space when said oven is erect, said rack being dimensioned for unmounted storage in the one of said storage compartments to which said top panel provides said closure.

3. The collapsible oven construction of claim 1 wherein said top and bottom panels are hingedly connected to their respective flange sections along lines which are offset outwardly with respect to the plane intersecting the hinged connections between the side panel sections and the side sections of the same flange means.

4. In a collapsible oven for a camp stove having stable erect and collapsed positions,  
 said oven being of rectilinear configuration and having an interior space enclosed by front, back, side, top and bottom panels,  
 the construction comprising:  
 storage compartment-providing flange means extending inwardly from the perimeter of said front and back panels,  
 said flange means including top, bottom, and side sections forming extensions, respectively, of said top, bottom, and side panels when said oven is in its erect position,  
 the inner facing sides of the storage compartments provided by said flange means being open when said oven is erect,  
 said side panels including vertical sections hingedly connected at their adjacent inner edge portions to fold inwardly so that the sections of each side panel are superposed when said oven is collapsed,  
 the outer vertical edge portions of said side panel sections being hingedly connected to the respective in-

ner edge portions of said flange means side sections, one of the outer edge portions of said top panel being hingedly connected to the inner edge portion of the top section of one of said flange means,  
 one of the outer edge portions of said bottom panel being hingedly connected to the inner edge portion of the bottom section of the other of said flange means, each of said top and bottom panels being foldable inwardly when said oven is collapsed to form a closure respectively of one of the said facing sides of said storage compartments, said top panel forming a storage compartment with said front panel and said bottom panel forming a storage compartment with said back panel,  
 said top and bottom panels being hingedly connected to their respective flange sections along lines which are offset outwardly with respect to the plane intersecting the hinge connections between the side panel sections and the side sections of the same flange means,  
 an outwardly opening hinged door forming a part of said front panel,  
 a detachable support rack for mounting to extend horizontally within said oven, said rack being dimensioned for unmounted storage in the one of said compartments formed by said top panel and said front panel, said rack being accessible through said front panel door for manipulation into and out of said storage compartment,  
 a flame and heat baffle mounted on the top of said bottom panel and projecting upwardly therefrom, said baffle being dimensioned for storage in the one of said storage compartments formed by said bottom panel and said rear panel, said baffle being insertable in its storage compartment as said oven is collapsed while remaining attached to said bottom panel.

5. In a collapsible oven for a camp stove having stable erect and collapsed positions,  
 said oven being of rectilinear configuration and having an interior space enclosed by front, back, side, top and bottom panels,  
 the construction comprising:  
 storage compartment-providing flange means extending inwardly from the perimeters of said front and back panels,  
 said flange means including top, bottom, and side sections forming extensions, respectively, of said top, bottom, and side panels when said oven is in its erect position,  
 the inner facing sides of the storage compartments provided by said flange means being open when said oven is erect,  
 said side panels including vertical sections hingedly connected at their adjacent inner edge portions to fold inwardly so that the sections of each side panel are superposed when said oven is collapsed,  
 the outer vertical edge portions of said side panel sections being hingedly connected to the respective inner edge portions of said flange means side sections, one of the outer edge portions of said top panel being hingedly connected to the inner edge portion of the top section of one of said flange means,  
 one of the outer edge portions of said bottom panel being hingedly connected to the inner edge portion of the bottom section of the other of said flange means, each of said top and bottom panels being foldable inwardly when said oven is collapsed to form a closure respectively for one of the said facing sides of said storage compartments, and  
 latching means for latching respectively said top and bottom panels in their erect positions and for latching said oven in its collapsed position,  
 said latching means including at least two dual function latches,  
 one of said latches being effective to latch said top

9

panel in its erect position, the other of said latches being effective to latch said bottom panel in its erect position, both of said latches also being effective to latch said oven in its collapsed position.

6. The collapsible oven construction of claim 5 wherein each of said latches includes a lever having an outwardly-extending operating arm, an inwardly-extending latching arm, and a central position pivotally connected to the one of said flange sections which forms an extension of the one of said top and bottom panels latched thereby in its erect position, said latching arm cooperating with the adjacent edge portion of the said latched panel to form a connection therewith which can be selectively secured and released by moving said operating arm, said latched panel also providing a slot therein in a position opposite said latching arm when said latched panel is in its collapsed position, and said latching arm being movable into and out of said slot by means of said operating arm for selectively securing and releasing said latching arm to said panel.

7. In a collapsible oven for a camp stove having stable erect and collapsed positions,

said oven being of rectilinear configuration and having an interior space enclosed by front, back, side, top and bottom panels,

the construction comprising:

storage compartment-providing flange means extending inwardly from the perimeters of said front and back panels,

said flange means including top, bottom, and side sections forming extensions, respectively, of said top, bottom, and side panels when said oven is in its erect position,

the inner facing sides of the storage compartments provided by said flange means being open when said oven is erect,

said side panels including vertical sections hingedly connected at their adjacent inner edge portions to fold inwardly so that the sections of each side panel are superposed when said oven is collapsed,

the outer vertical edge portions of said side panel sections being hingedly connected to the respective inner edge portions of said flange means side sections, one of the outer edge portions of said top panel being hingedly connected to the inner edge portion of the top section of one of said flange means,

one of the outer edge portions of said bottom panel being hingedly connected to the inner edge portion of the bottom section of the other of said flange means, each of said top and bottom panels being foldable inwardly when said oven is collapsed to form a closure respectively for one of the said facing sides of said storage compartments,

said top and bottom panels being hingedly connected to their respective flange sections along lines which

10

are offset outwardly with respect to the plane intersecting the hinge connections between the side panel sections and the side sections of the same flange means,

5 a detachable support rack for mounting to extend horizontally within said oven, said rack being dimensioned for unmounted storage in the one of said compartments to which said top panel provides said closure,

10 a flame and heat baffle mounted on the top of said bottom panel and projecting upwardly therefrom, said baffle being dimensioned for storage in the one of said storage compartments to which said bottom panel provides said closure, and

15 latching means for latching respectively said top and bottom panels in their erect positions and for latching said oven in its collapsed position, said latching means including at least two dual function latches,

20 one of said latches being effective to latch said top panel in its erect position, the other of said latches being effective to latch said bottom panel in its erect position, both of said latches also being effective to latch said oven in its collapsed position.

25 8. The collapsible oven construction of claim 7 wherein each of said latches includes a lever having an outwardly-extending operating arm, an inwardly-extending latching arm, and a central position pivotally connected to the one of said flange sections which forms an extension of the one of said top and bottom panels latched thereby in its erect position, said latching arm cooperating with the adjacent edge portion of the said latched panel to form a connection therewith which can be selectively secured and released by moving said operating arm, said latched panel also providing a slot therein in a position opposite said latching arm when said latched panel is in its collapsed position, and said latching arm being movable into and out of said slot by means of said operating arm for selectively securing and releasing said latching arm to said panel.

#### References Cited by the Examiner

##### UNITED STATES PATENTS

45	963,769	7/1910	Johnson et al. ....	312—262 X
	1,456,382	5/1923	Kincannon .....	126—275
	2,454,571	11/1948	Rom .....	126—275
	2,576,750	11/1951	Clark .....	312—259
	2,934,389	4/1960	Krey .....	312—262 X

##### FOREIGN PATENTS

23,041 1914 Great Britain.

FREDERICK L. MATTESON, JR., *Primary Examiner.*

55 E. G. FAVORS, *Assistant Examiner.*