

Feb. 17, 1970

W. J. TOWNSEND

3,496,349

DETACHABLE STORAGE COMPARTMENT FOR LANTERN

Filed Dec. 30, 1966

2 Sheets-Sheet 1

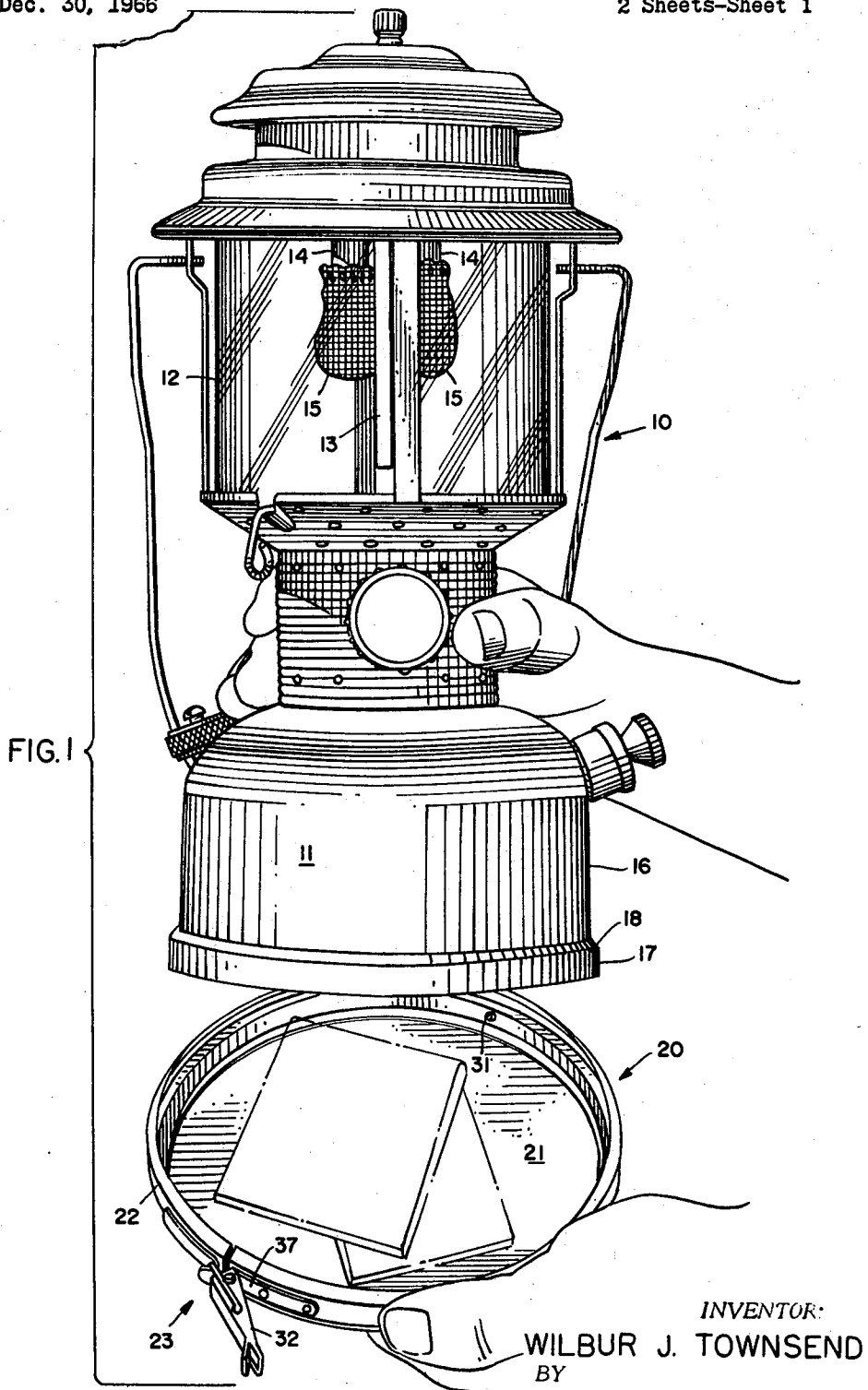

INVENTOR:

WILBUR J. TOWNSEND

BY

Dawson, Dilroy, Falloy, Lungmuir & Alexander
ATT'YS

Feb. 17, 1970

W. J. TOWNSEND

3,496,349

DETACHABLE STORAGE COMPARTMENT FOR LANTERN

Filed Dec. 30, 1966

2 Sheets-Sheet 2

FIG. 2

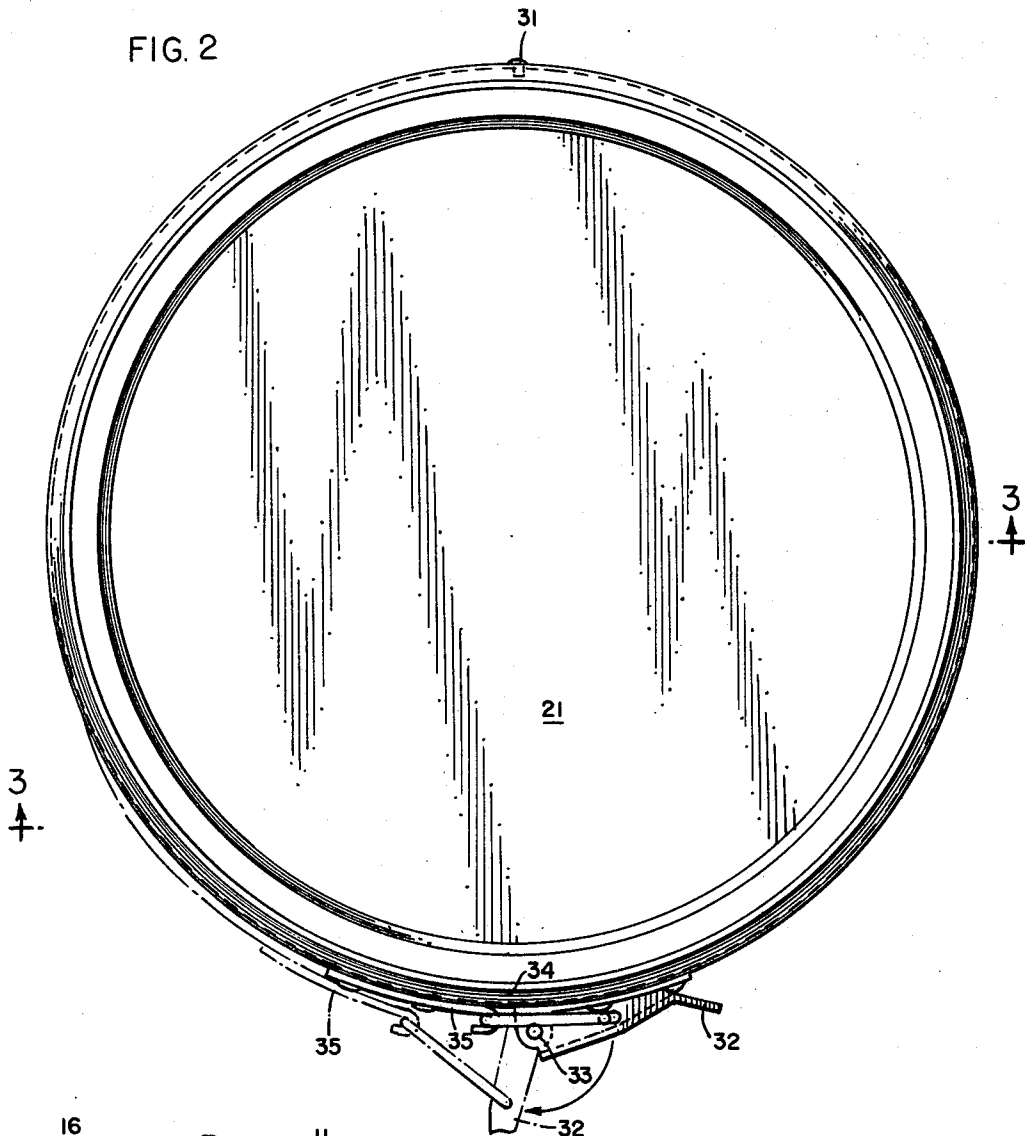
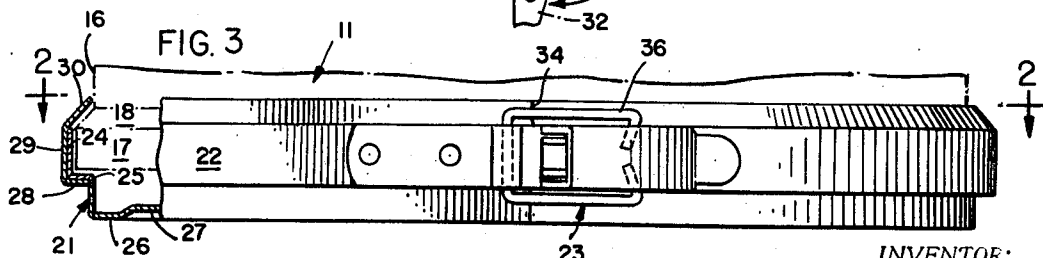

FIG. 3



INVENTOR:

WILBUR J. TOWNSEND
BY

Dawson, Dilroy, Falloy, Luinguis & Alexander
ATT'YS

1

2

3,496,349

DETACHABLE STORAGE COMPARTMENT FOR LANTERN

Wilbur J. Townsend, Wichita, Kans., assignor to The Coleman Company, Inc., Wichita, Kans., a corporation of Kansas

Filed Dec. 30, 1966, Ser. No. 606,196

Int. Cl. F21v 19/00

U.S. Cl. 240—50

5 Claims

ABSTRACT OF THE DISCLOSURE

A detachable storage compartment is disclosed for attachment to the base shell of a gasoline lantern. The compartment includes a shallow pan and a split draw band located about the pan and adapted to fit over a lower peripheral rim of the base of the lantern. A draw bolt latch secures the split ends of the draw band together in locked coupling with the lantern.

BACKGROUND OF THE INVENTION

This invention relates to gasoline lanterns; and more particularly, this invention relates to a detachable compartment for storage of accessories used with the lantern.

In conventional gasoline lantern, various operating elements are subject to deterioration through use and these elements must be periodically replaced in order to maintain the lantern in an operative condition. In addition, the lantern might require special wrenches or tools for use in changing these replaceable elements. Heretofore, such elements and tools were kept as the user pleased with no special place provided for their safekeeping.

SUMMARY

The present invention obviates the problem of safekeeping replaceable elements and tools for use with a gasoline lantern by providing a detachable accessory compartment secured beneath the lantern thereby forming a false bottom in the lantern for storage of replaceable elements, tools, matches and the like. A user can then replace burned-out or used elements as is required without the need for hunting for the elements and their associated tools; and he has at his hand any other accessories associated with the use of the lantern.

Other advantages of the present invention will be obvious to those skilled in the art from the following detailed description accompanied by the attached drawing.

THE DRAWING

FIG. 1 illustrates a preferred accessory compartment being secured to the base of a conventional gasoline lantern;

FIG. 2 is a top view of an accessory compartment according to the present invention showing it in both a locked and unlocked position; and

FIG. 3 is a partially-sectioned side view of the accessory compartment of FIG. 2.

DESCRIPTION

Referring then to the drawing, like reference numerals will refer to identical elements in the various views. In FIG. 1 is shown a conventional gasoline lantern designated generally as 10. The lantern 10 has a base shell 11 for receiving and containing fuel. A cylindrical transparent globe 12 encloses a hollow tubular generator 13 and a pair of burner caps 14 and their associated mantles 15.

The mantles 15 eventually break during the burning of the fuel, and therefore must be replaced from time to time. The tubular generators 13 must also be periodically replaced as they deteriorate with use; and they are usually replaced at the same time that new mantles are installed. These replaceable elements are the ones which the present invention is primarily designed to store together with any tools required for their replacement.

As can be seen in FIG. 1, the base shell 11 has a cylindrical side wall 16. Integral with and at the base of cylindrical side wall 16 is an enlarged rim 17 for supporting the lantern assembly. An inwardly tapering flange 18 extends from the top of the rim 17 to the cylindrical side wall 16 to form a smooth outer surface for the base shell 11.

Still referring to FIG. 1, a detachable storage compartment is generally designated by reference numeral 20. Matches (as shown in the drawing) or the above-mentioned replaceable element (i.e., mantles and generators), may be kept in the storage compartment 20 for convenience.

Referring now to FIGS. 2 and 3, a preferred embodiment of a detachable storage compartment is illustrated. The storage compartment 20 comprises generally a drawn circular bottom or pan 21, a peripheral draw band 22 and a draw bolt latch, indicated generally as 23. The three parts form a unitary construction, as will be described.

The drawn circular pan 21 includes a vertical circular side wall 24 which has an inside diameter slightly larger than the outside diameter of rim 17 of the base shell 11 for ease of attachment, since the two lie adjacent one another when the compartment is assembled to the lantern. Integral with and interior of the lower part of the vertical side wall 24 is a horizontal annular seating plate 25 for receiving and limiting the downward motion of the lantern onto the accessory compartment by engagement with the rim 17. Depending from the horizontal seating member 25 is an annular foot 26 for supporting the lantern when the accessory compartment is attached. A circular plate 27 integral with the annular foot 26 forms the bottom of the pan 21. The bottom plate 27 lies in a plane below the seating plate 25, and the height of the accessory compartment is defined by the space between the bottom plate 27 of pan 21 and the bottom of the base shell 11, which may be somewhat above the bottom of the rim of shell 11.

The side band 22 comprises a horizontal annular flange 28, a vertical circular side wall 29 integral with the outer circumference of the flange 28 and a tapered or frustoconical member 30 integral with the top of the side wall 29 and extending upwardly and inwardly thereof.

The flange 28 and side wall 29 of the draw band 22 engage respectively the underside of the seating plate 25 and the side wall 24 of the bottom 21. As can be seen in FIG. 3, wherein the base shell 11 of the lantern 10 is shown in phantom, the outer surface of the peripheral rim 17 lies adjacent the inner surface of the vertical side wall 24 of the pan 21. When the draw bolt latch 23 is in a locked position, the pan 21 is securely attached to the lantern by means of the draw band which forms a circular channel for limiting relative motion between the rim 17 and the annular seating flange 25.

A single rivet 31 joins the side band 22 and pan 21 at their respective abutting side walls 29 and 24. The rivet 31, as most clearly seen in FIGS. 1 and 2, is located diametrically opposite the draw bolt latch 23.

Referring now to FIG. 2, the draw bolt latch 23 is shown

in a locked position in the solid lines, and in an open position in the dashed lines. With the draw bolt latch 23 in an open position, the unitary accessory compartment 20 may easily be attached to the bottom of the lantern 10, as will be explained in more detail below.

As can be seen, the draw latch is conventional and consists of a handle or lever 32 pivotally connected as at 33 to a pivot link 37 attached to the draw band 22 for pivotal motion in its plane. The draw band 22 is split vertically, as shown at 34, with the pivotal connection 33 for the handle 32 on one side of the split 34. On the other side of the split 34, a hooking member 35 is fixed, as by riveting, to the side wall 29 of draw band 22.

A buckle 36 is pivotally hooked by the hooking member 35 and has an open end pivotally connected to the lever 32 with the pivotal connection 33 intermediate its ends when the latch is locked. Hence, when the lever 32 is drawn away from the draw band 22, the buckle 36 releases the hooking member 35, and the draw band 22 expands thereby allowing the lantern 10 to be pulled from the storage compartment 20. When the lever 32 is pushed adjacent the draw band 22, the buckle 36 draws the hooking member 35 toward the pivotal connection 33, and closes the gap in the split 34 thereby contracting the draw band 22 to a locked position and securing the compartment 21 to the lantern 10.

The draw band 22 is resilient and, therefore, capable of being forced to an expanded state; but in its normal position, the inner circumference of the tapered section 30 is less than the circumference of the rim 17 of lantern 10 for snapping over it, for reasons which will presently be explained.

With the accessory compartment thus described, it can be seen that a unitary compartment is formed which can be releasably secured to the bottom of the shell base 11 of the lantern 10. As will be appreciated from FIG. 1, the storage compartment 20 may be assembled to the bottom of shell base 11 as follows. With the lantern in one hand, and the storage compartment, together with any accessories that are to be stored in it, in the other hand, the plane defining the bottom edge of the rim 17 of the lantern 10 is inclined relative to the plane of the bottom plate 27 of the compartment 20, and the lowermost portion of the bottom edge of rim 17 is forced to engage the seating member 25 of the compartment 20 adjacent the pivot 31. At this time, the draw bolt latch 23 is in an unlocked position.

The compartment 20 and lantern 10 are then rotated together while maintaining contact opposite the latch. The bottom edge of the rim 17 urges the upper edge of the tapered section 30 of compartment 20 into an expanded condition which allows the compartment 20 to snap onto the lantern 10, and the lower edge of the rim 17 is seated on the seating member 25, as shown in FIG. 3.

It will be noted that with the compartment 20 thus assembled onto the lower rim 17 of the lantern 10, the taper 30 of the draw band 22 will engage the taper 18 on the base shell 11 on the lantern 10 and hold the compartment 20 and its contents to the lantern even though the draw bolt latch 23 is not locked. Hence, the one hand may be removed from supporting the compartment 20 thereby freeing it to fasten the latch 23 by forcing the lever 32 against the side of the draw band 22, as previously explained. This action then secures the compartment 20 to the base shell 11, and it cannot be removed without unlocking the latch 23. This feature of having a resilient or expandable draw band 22 with a normal circumference sufficient to hold the compartment 20 and its contents to the shell base 11 without having the latch 23 in a locked position, is considered an important advantage of the above-described structure in that it leaves one hand free to secure the latch after the compartment has been attached to the base shell.

Although it will be recognized by those skilled in the art that equivalent materials may be substituted for those

which we have found suitable, it is noted that preferred material for the pan 21 is aluminum; for the draw band 22, stainless steel; and for the latch 23, zinc-plated steel.

With the structure thus described, a person skilled in the art will be able to substitute equivalent structure or material without departing from the principle of my invention; and it is intended that such substitutions and modifications be covered as they are embraced within the spirit and scope of the appended claims.

I claim:

1. In combination, a lantern including a base shell having a cylindrical side wall with a peripheral rim about the bottom of said side wall and providing an integral inclined surface extending from the top of said rim inwardly and upwardly to said side wall; and a storage compartment removably secured to said base shell comprising a shallow circular pan having a cylindrical side wall terminating at its lower edge in a horizontal flange providing a seat for the bottom of said peripheral rim of said shell, a resilient draw band secured to said pan having a cylindrical side wall exterior of the side wall of said pan and terminating in a lower horizontal flange for engaging the lower surface of said horizontal seat flange of said pan, said draw band being split to define first and second ends and further including an upper tapered portion inclined inwardly of said wall of said band for placement over the inclined surface of said shell when said compartment is attached thereto, and a latch for selectively drawing the split ends of said band together and locking the same in securing said compartment to said lantern.

2. The structure of claim 1 characterized in that said split draw band is capable of assuming an expanded and a contracted position, said draw band normally assuming a state of expansion so that the upper tapered portion thereof defines an inner circumference less than the outer circumference of the rim of said base shell of said lantern, whereby with said latch in an open position, said compartment may be held in one hand and said lantern attached thereto by inserting the lower rim of said base shell within said draw band with the inclined portion of said draw band resting against the inclined surface of said base shell and said compartment is held thereagainst without being fastened to said base shell.

3. The structure of claim 2 wherein said latch comprises a buckle pivotally connected to said draw band on one side of said split, and a lever pivotally connected to said draw band on the other side of said split, said lever receiving said buckle whereby said draw band is forced to a constricted position when said lever is forced away from the split in said draw band.

4. The structure of claim 1 wherein said pan further defines an annular foot member in the bottom thereof for supporting said lantern and said compartment.

5. A detachable storage compartment for a lantern including a base shell having a cylindrical side wall and a peripheral rim about the bottom edge of said side wall, said rim including an upper inclined surface extending from the top of said rim inwardly and upwardly to said side wall, comprising: a shallow circular pan having a cylindrical side wall terminating at its lower edge in a horizontal flange providing a seat for the bottom of said peripheral rim of said shell; a resilient draw band secured to said pan having a cylindrical side wall exterior of the side wall of said pan and terminating in a lower horizontal flange for engaging the lower surface of said horizontal seat flange of said pan, said draw band being split to define first and second ends and further including an upper tapered portion inclined inwardly of said side wall of said band for placement over the inclined surface of said shell ridge when said compartment is attached thereto, and a latch for selectively drawing the split ends of said band together and locking the same in securing said compartment to said lantern, whereby with said latch in an open position, said compartment

5

may be held in one hand and said lantern attached there-
to by inserting a lower rim of said base shell within said
draw band with the inclined portion of said draw band
resting against the inclined surface of said base shell rim
and said compartment is held thereagainst without be-
ing fastened to said base shell.

References Cited

UNITED STATES PATENTS

744,952	11/1903	Betts	240—50	10
832,815	10/1906	Schendewolf	240—50	
1,689,085	10/1928	Russell et al.	220—550	

6

2,599,253	6/1952	Gits	240—10.67
2,599,295	6/1952	Thomas	240—10.66

FOREIGN PATENTS

531,767	8/1955	Italy.
---------	--------	--------

NORTON ANSHER, Primary Examiner

R. M. SHEER, Assistant Examiner

U.S. Cl. X.R.

220—55; 240—98